

GRIFFITH PARK OBSERVATORY

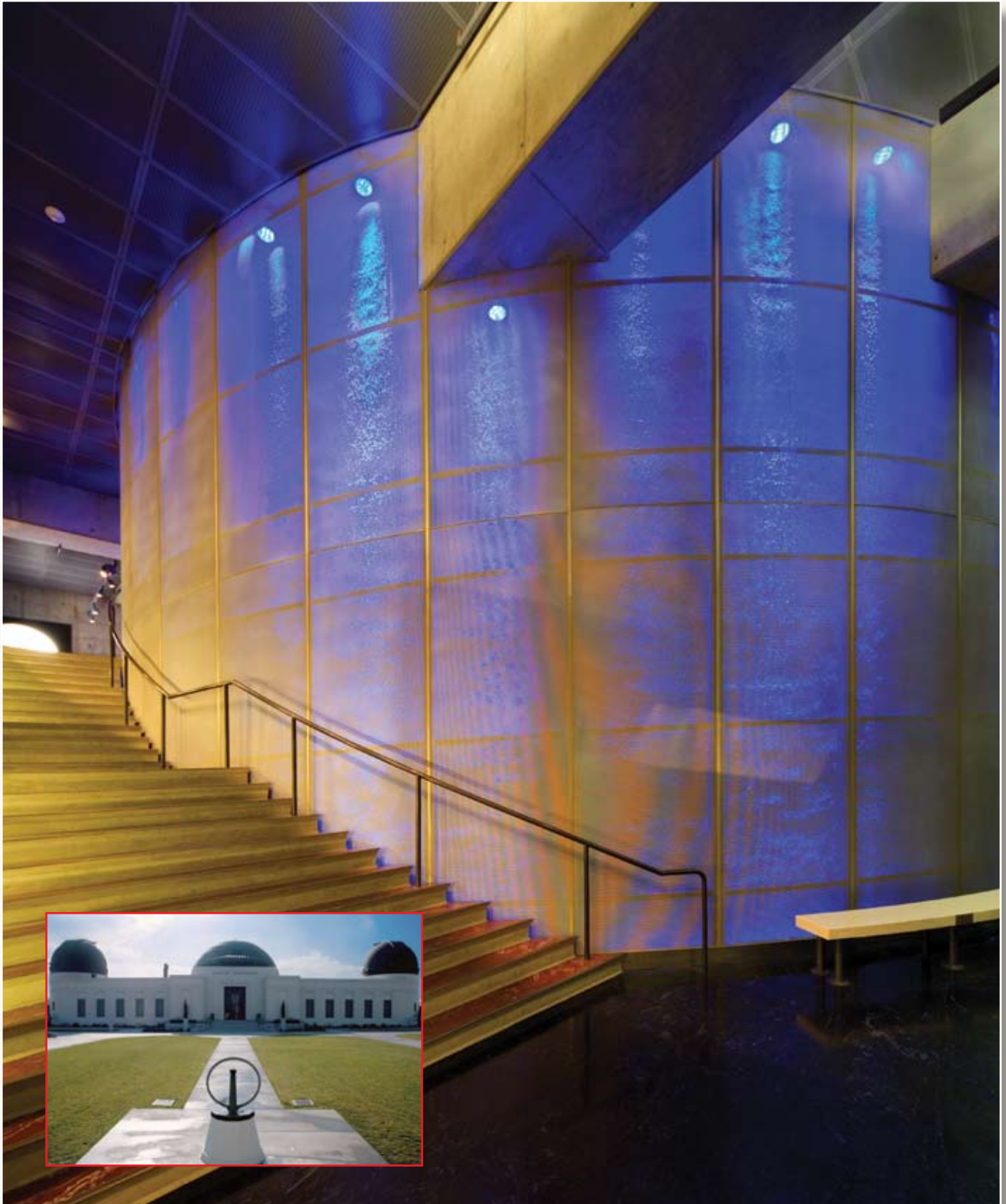

GRIFFITH PARK OBSERVATORY



DETAILS

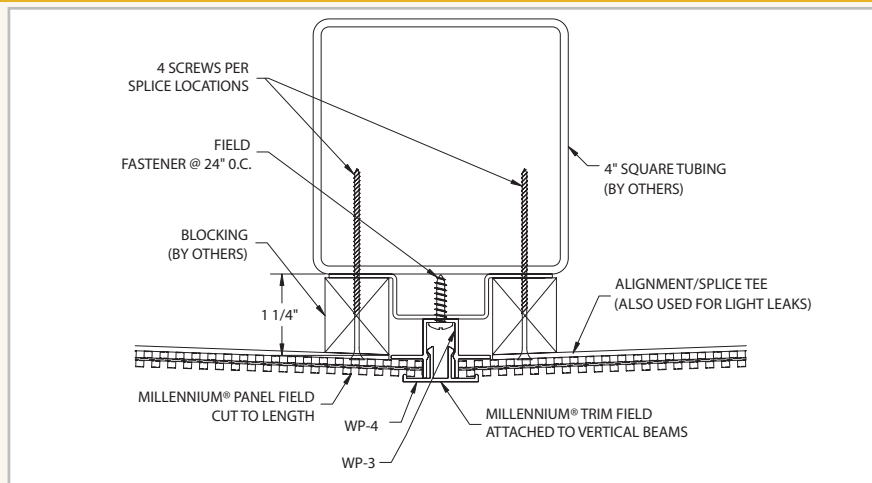

Gordon provided:

- MILLENNIUM® Aluminum Wall System Solutions
- Panels: MILLENNIUM® Tubular Aluminum
- Open Area: 40% open area
- Finish: ACROGUARD® Asti II High Performance Powder Coat
- Trim: Standard 2 piece snap trims

**2006 CISCA Construction
Excellence Award Winner**
**Best in Category -Restoration/Renovation
West Region**

PROJECT

Griffith Park Observatory
Los Angeles, CA

ARCHITECT

Hardy, Holzman, Pfeiffer Associates (HHPA)
Los Angeles, CA

GORDON REPRESENTATIVE

Specified Designs
La Canada, CA

CONTRACTOR

EA Environmental Construction
Agoura Hills, CA
Amoroso Construction
Costa Mesa, CA

GORDON
INTERIOR SPECIALTIES DIVISION

5023 HAZEL JONES ROAD

BOSSIER CITY, LA 71111

800.747.8954

800.877.8746 FAX

SALES@GORDONCEILINGS.COM

GORDONCEILINGS.COM

